

principle and characteristics

Based on the thermal principle, the sealed probe contains two resistors, one of which is not heated as the detection resistor, the other is not heated as the reference resistor. When the medium flows, the heat on the heating resistor is taken away, the resistance value is changed, and the difference between the two resistors is used as the basis to judge the flow rate. No moving parts, maintenance-free, easy installation, one model is suitable for a variety of pipe diameter requirements, switching continuously adjustable, extremely low pressure loss, compact structure, LED display flow trend and switch status.

product applicatio

Pneumatic and hydraulic dual purpose, low flow rate alarm, can be used for pneumatic and hydraulic systems, can be used for circulating water, cutting fluid and lubricating oil cut-off detection, and pump idling protection.

wiring diagram

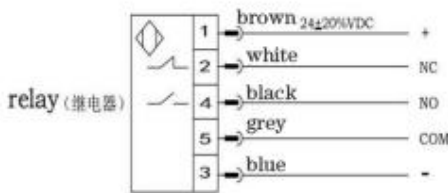
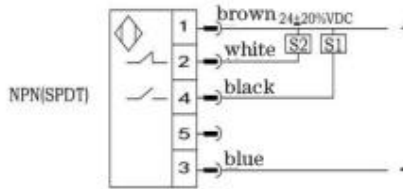
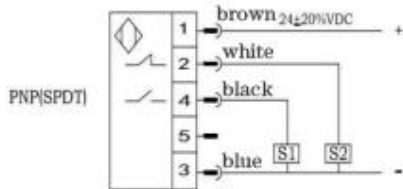

technical specification

- ◆ setting range: 1...150cm/s(water)
3...300cm/s(oil) ,
20...2000cm/s(air)
- ◆ Signal output: PNP,NPN, relay normally open + normally closed (SPDT)
- ◆ Power supply: 24V ± 20%DC or 230V ± 15%AC
- ◆ Switch on current: maximum 400mA(PNP or NPN type)
Maximum 1A@48V (relay type)
- ◆ No-load current: Max. 80mA
- ◆ Flow indicator: LED row (6)
- ◆ setting mode: potentiometer setting
- ◆ Voltage range: 100bar
- ◆ Temperature gradient: ≤4° C/S
- ◆ Response time: 1-13s, typical 2s
- ◆ initialization time: about 8s
- ◆ Electrical protection: reverse phase, short circuit, overload protection
- ◆ Protection grade: IP67
- ◆ Medium temperature: -20-80° C
- ◆ Ambient temperature: -20-80° C
- ◆ Storage temperature: -20-100° C
- ◆ Wiring mode: M12 connector/optional with 2 meters wire directly
- ◆ Material: Probe: stainless steel
- ◆ shell: PBT
- ◆ Weight: 约0.4kg

dimension figure

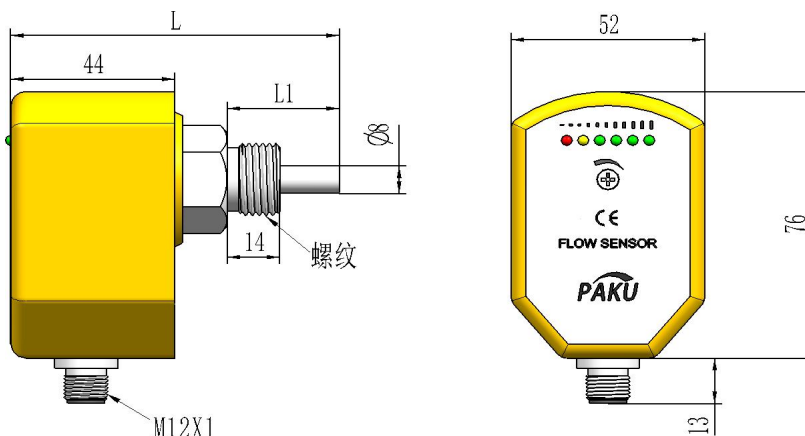

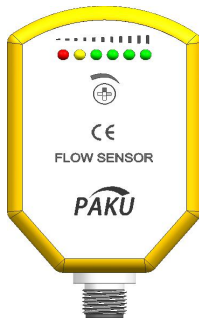

LDE function and setting (on/off type)

<input type="radio"/> Red LED light	<input type="radio"/> Yellow LED light	<input type="radio"/> Yellow and green
<input type="radio"/> Disconnection or flow rate	<input type="radio"/> The flow rate equals the set point	<input type="radio"/> LED light on: flow
<input type="radio"/> Below the set value	<input type="radio"/> Value switch action	<input checked="" type="radio"/> The flow rate is greater than the set value
<input type="radio"/> Switch to release	<input type="radio"/>	<input checked="" type="radio"/> The greater the green variable, the greater the flow rate
<input type="radio"/>	<input type="radio"/>	<input type="radio"/>
<input checked="" type="radio"/>	<input type="radio"/>	<input type="radio"/>

installation instructions

For vertical installation, it should be installed on the pipe section flowing from bottom to top. When mounted horizontally, the probe should be kept away from air and sediment.

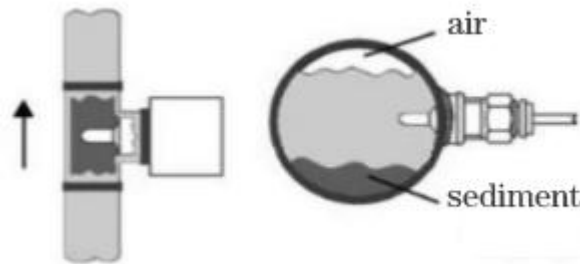

Selection table

SN10-	G2H	A	3	1	X	A	30	specification
SN10-								SN10 series electronic flow switch
	M1K							Interface thread M18*1.5 internal thread With the installation accessories, it is convenient to rotate and adjust the installation direction on
	G2H							Interface thread G1/2 female thread
	G4H							Interface thread G1/4 male thread
	K5							Chuck connection (outside diameter 50.5mm)
								Custom threads, such as NPT1/2, type N12
		A						DC DC24V ± 20% power supply
		B						AC AC230V ± 15% power supply
			1					PNPoutput
			2					NPNoutput
			3					relay output
				1				Normally open + normally closed output
					X			Probe material: 304 stainless steel
					XL			Probe material: 316L stainless steel
						A		Connector type (standard with 2 meters of wire)
						B		Straight out
							30	Probe rod length unit mm (including thread)
							L	Customized probe rod length unit mm (including

* The factory is standard equipped with electrical accessories M12 connector type ZL05-PU02FG
 * Select M18*1.5 internal thread installation mode, please pay attention to the selection of installation accessories
 * Customizable thread, H for external thread, K for internal thread
 * For selection of electrical accessories and installation accessories, please refer to the appendix page on page –
 * The selection table is only available for parameter selection, and the corresponding code is delivered.